

Pietranera Pentawash

Determine the correct working position for the washing unit by using the outline in figure 2.

Remove the two rear casings in stainless steel indicated by the letter B (figure 1) and attach the washing unit to the anchoring bolts using holes F (figure 2).

Remove lower shelf P (figure 1) and in the surrounding area (indicated in figure 2 by dotted line) make the water connections with the shop system.

If the water system is not on the floor but on the wall, the connection must be made by resting the washing unit against the wall, eliminating side panel L (figure 2).

Cut the copper pipes of the mixer to the length indicated in figure 3.

Fit the mixer unit on the wash basin and drain pipes.

Connect plates P to the wash basins using brass screws. The rubber washer N must be placed in the upper part inside the wash basin.

Insert the wash basin units on the washing unit.

Remove the rear cover V, loosening the lateral stops C (figure 1).

Connect the wash basin drain pipes to the internal collectors C, securing them with the clamps.

Connect the hot and cold water delivery pipes to the mixers.

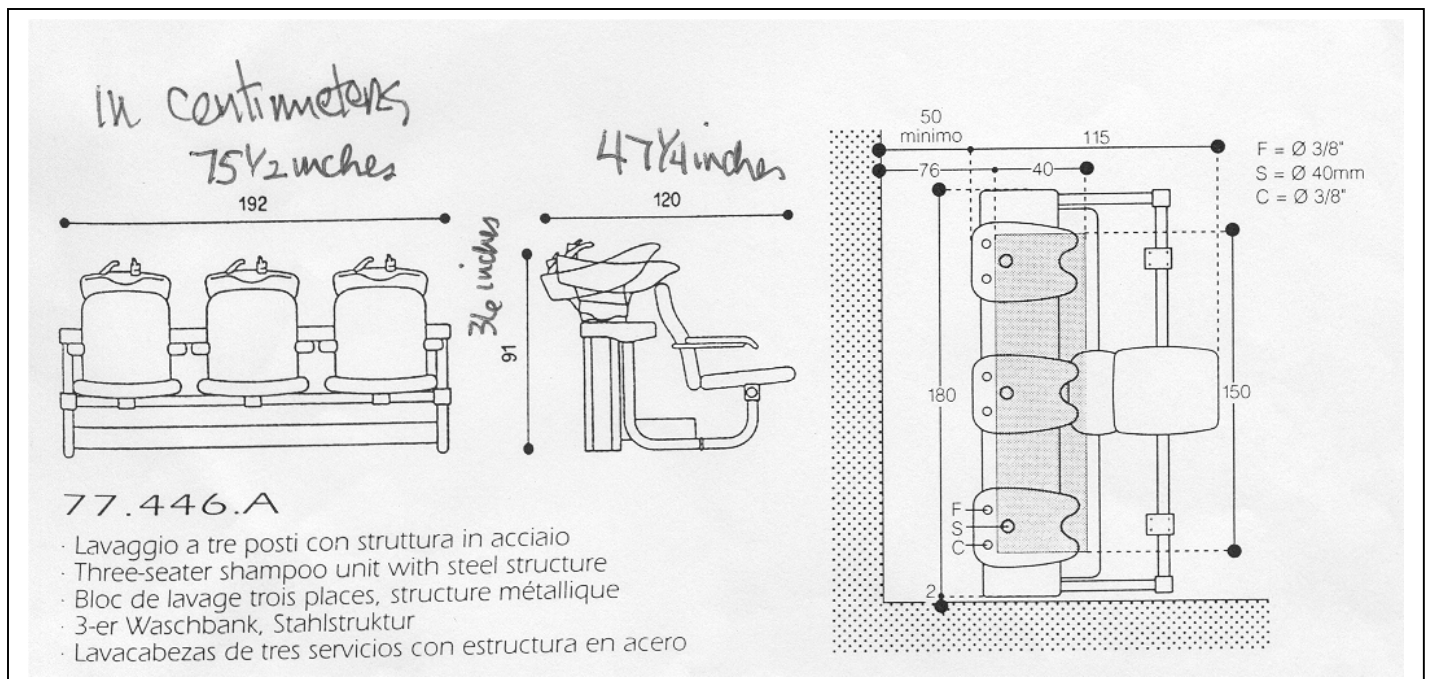

FIG. 1

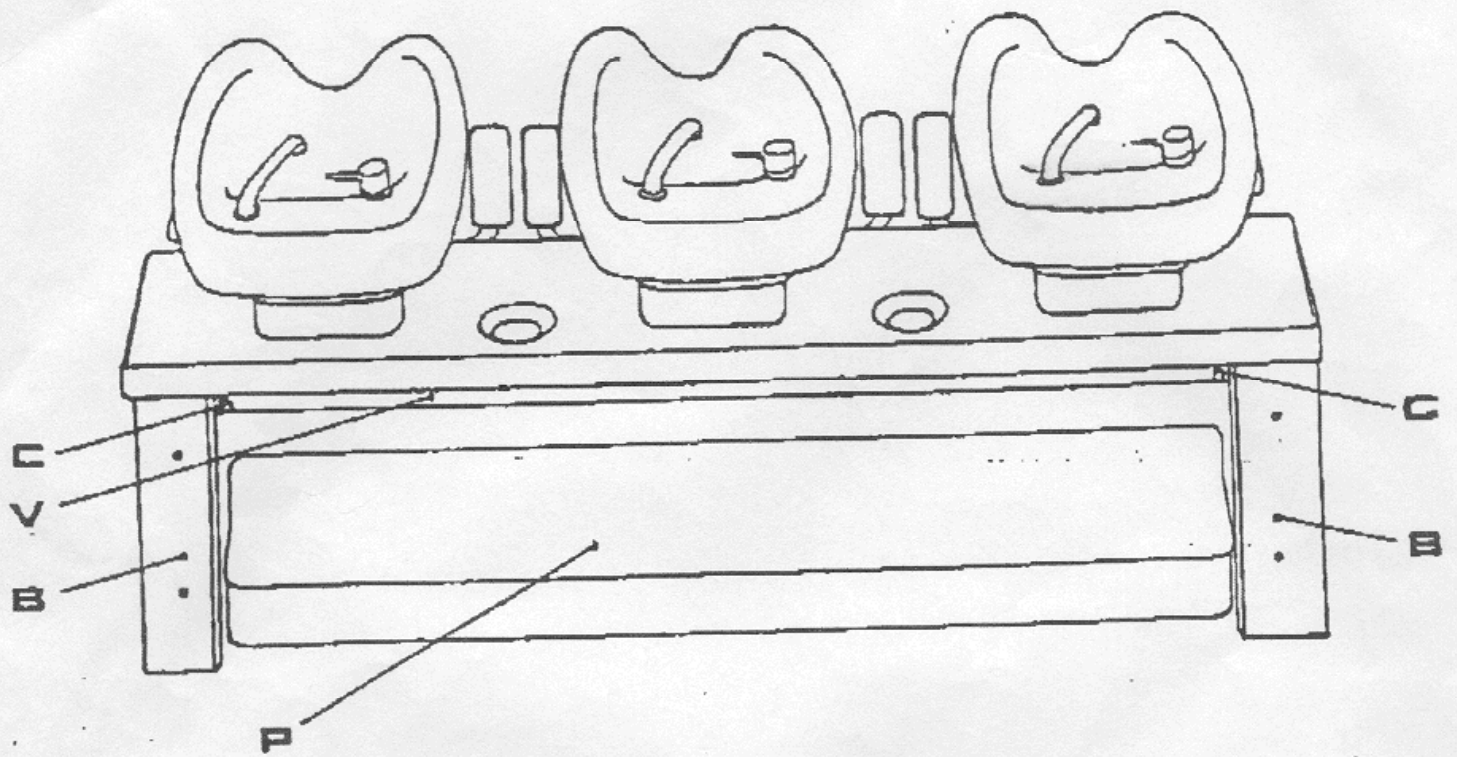

FIG. 4

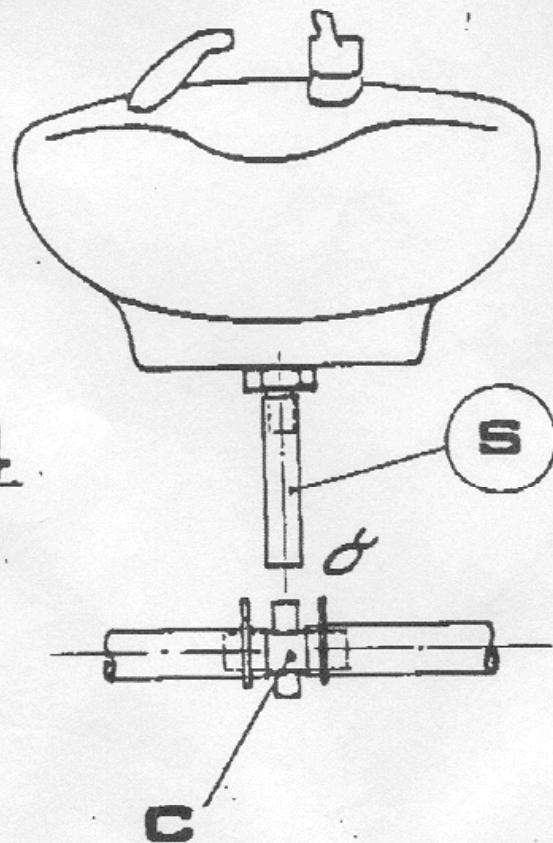
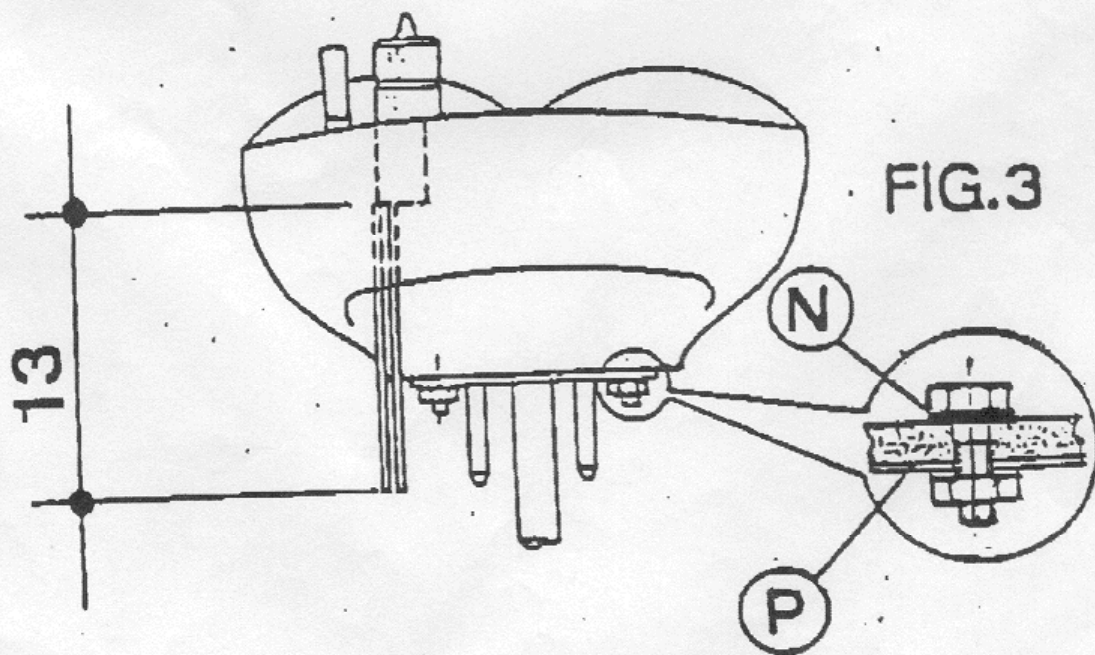
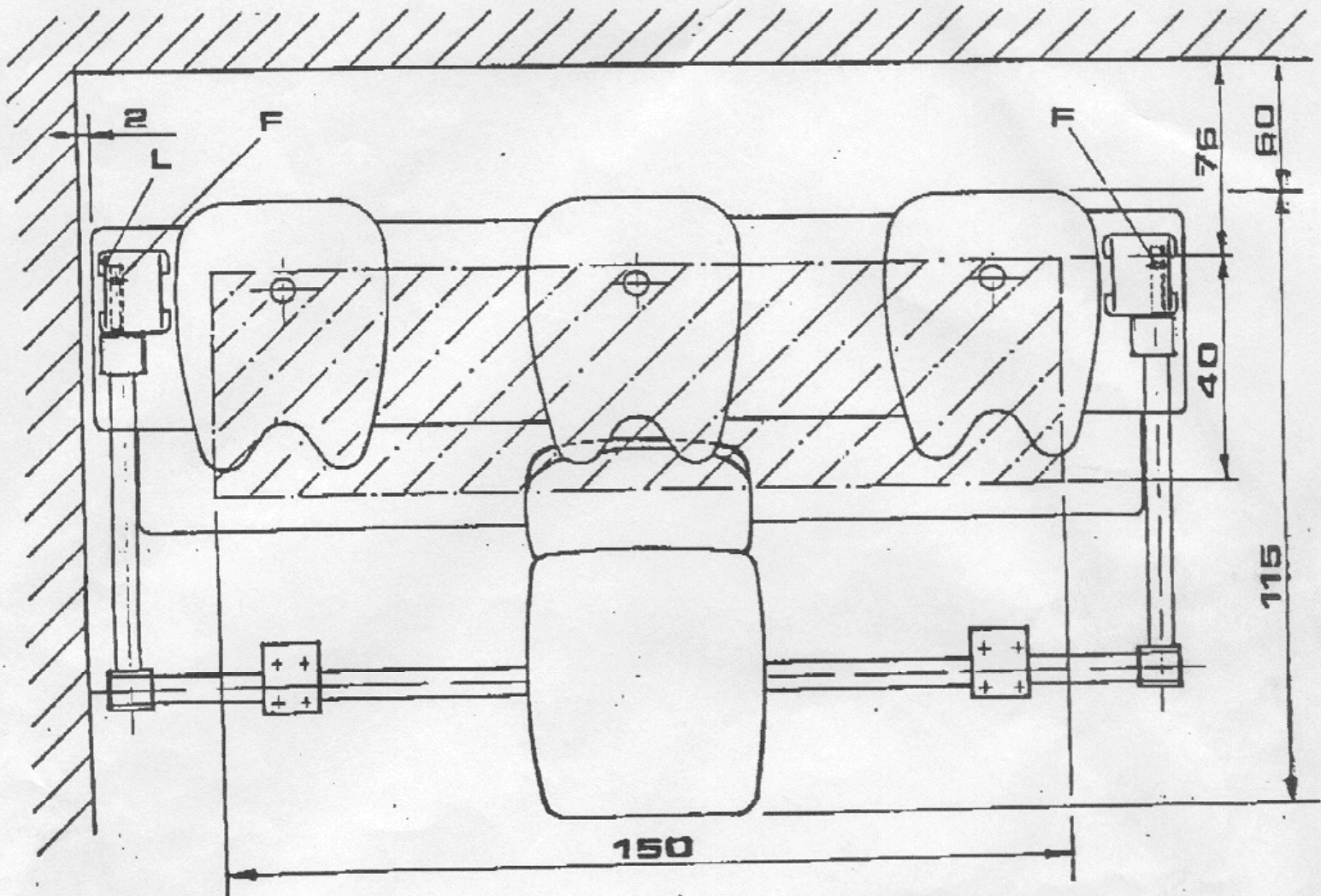

FIG. 2



ART. 445

ART. 446

